

|"DOUBLE CHAIN" シリーズ用 オプション |

OPTIONS FOR DOUBLE CHAIN SERIES / OPCION PARA DOUBLE CHAIN SERIES / 双重环系列用的附属品

■ B, BLX (B-2000, BLX2200)



■ BK-20 ベルトループカッター  
Automatic cutting device for belt loops.  
Cortador para pasadores.  
切带装置

■ SX



■ CS-2 空環切り装置 (写真はFSX用で類似品)  
ELECTRIC CHAIN CUTTER  
CORTADOR DE CADENETA  
切空线头装置

■ DLR

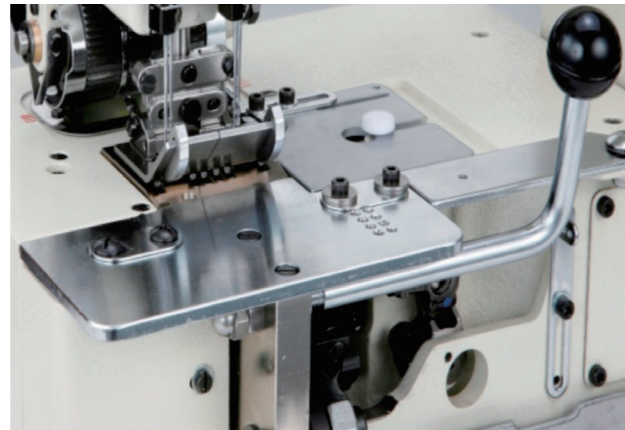

■ TB ターンダウンホルダーブラケット (\*1508SPF,1509SPFは標準装備)  
TURN DOWN FOLDER BRACKET (\*This is standard equipment for 1508SPF,1509SPF.)  
EQUIPAMENTO ESTANDAR (PARA 1508SPF, 1509SPF)  
拉开式面板 (1508SPF,1509SPF 标准装备)

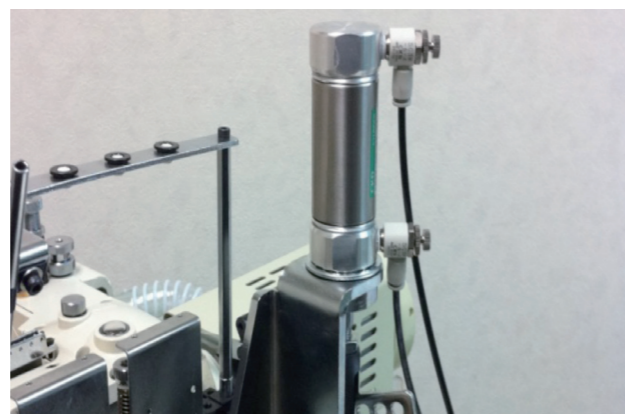

■ FL エアー式押え上装置  
AIR TYPE FOOT LIFTER  
LEVANTA PIE NEUMATICO  
气压式抬压脚装置

|"Multi-needle" シリーズ用 オプション |

OPTIONS FOR MULTI-NEEDLE SERIES / OPCION PARA MULTI-NEEDLE SERIES / 多针机的附属品

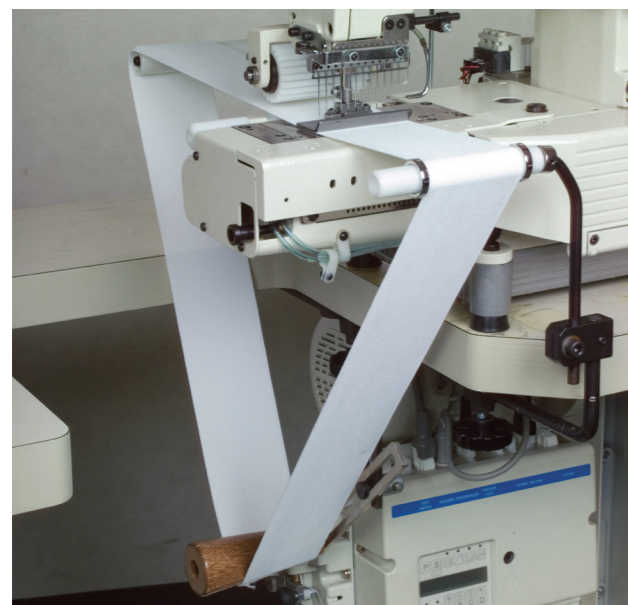

■ RT-1 ゴム張り装置 (手動式)  
DX, FX (PSF, PMD, PLは除く), RX (RX-P, PLKのみ)  
RT-1 Elastic expander device ( manual operation )  
DX, FX (except for PSF, PMD, PL), RX ( Only for RX-P, PLK )  
RT-1 EXPANDIDOR DE ELASTICO DX, FX, RX  
松紧带撑开装置 (DX,FX, 除PSF, PMD, PL, RX-P, PLK)

|"TOP & BOTTOM" シリーズ用 オプション |

OPTIONS FOR TOP & BOTTOM SERIES / OPCION PARA TOP&BOTTOM SERIES / 绷缝系列特殊配件

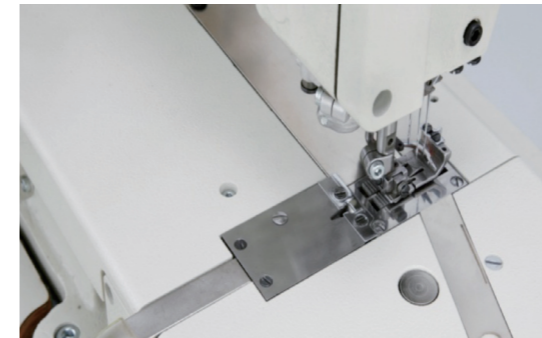

■ CS-1 空環切り装置 (VD 集塵装置は別売り)  
AIR TYPE CHAIN CUTTER ( Except for VD -Venturi device )  
CORTADOR DE CADENETA  
切空线头装置

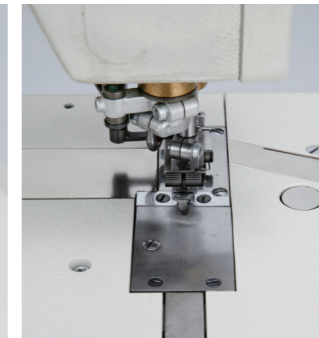

■ VD 集塵装置  
VENTURI DEVICE  
APARATO ASPIRADOR  
吸尘装置

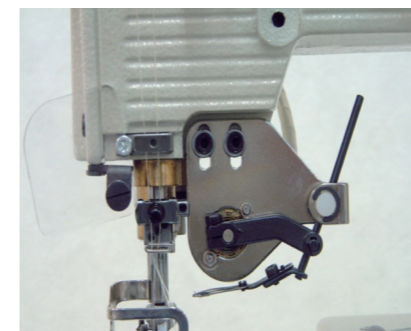

■ EW 電気式上糸払い  
(電気式ワイパー WX, RX, NM 用)  
ELECTRIC TYPE WIPER FOR WX, RX, NM  
DESILIZADOR ELECTRICO PARA WX, RX, NM  
电动式上勾线



■ AW エアー式上糸払い  
(エアー式ワイパー WX, RX, NM 用)  
AIR TYPE WIPER FOR WX, RX, NM  
DESILIZADOR NEUMATICO PARA WX, RX, NM  
气动式上勾线



■ MC-30 電気式テープカッター (WX-F, WX-15用)  
ELECTRIC TAPE CUTTER  
(For WX-F, WX-15)  
APARATO DE CORTA CINTA,  
TIPO ELECTRICO  
(PARA WX-F, WX-15)  
电动式切布装置



■ CS-2 空環切り装置 (FSX用)  
ELECTRIC CHAIN CUTTER (For FSX )  
CORTADOR DE CADENETA PARA FSX  
切空线头装置

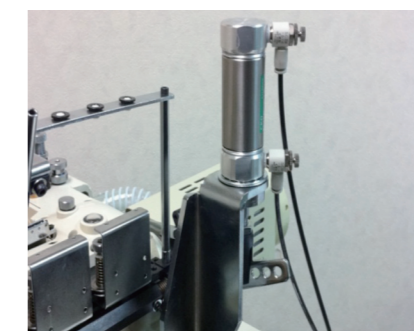

■ FL エアー式押え上装置  
AIR TYPE FOOT LIFTER  
FL: LEVANTA PIE NEUMATICO  
气压式抬压脚装置

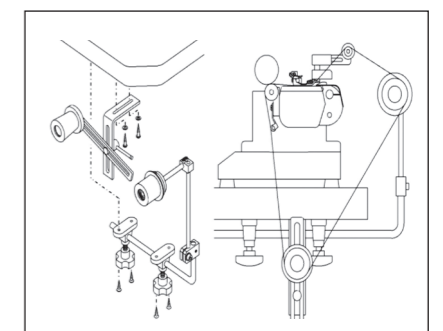

■ RT-1 ゴム張り装置 (手動式) RX-PHK  
Elastic expander device  
( manual operation ) RX-PHK  
EXPANDIDOR DE ELASTICO RX-PHK  
松紧带撑开装置

■ 00-6604 FSX 太径パイプ bigger diameter pipe (For FSX)



標準装備 / STANDARD DEVICE  
EQUIPAMENTO ESTANDAR / 标准配件

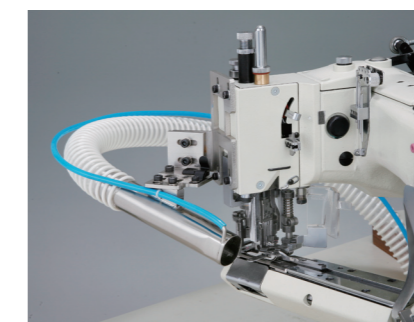

オプション / OPTION  
OPCIÓN / 选项

■ VD  
バキューム装置は標準装備 (FSX用)  
但し、写真右の太径は厚物用でオプション  
(パーツNo.00-6604)  
Vacuum equipment is standard device. (For FSX) But,  
in case of thick material, the bigger diameter pipe  
(PartsNo.00-6604) is available as per attached picture.  
Aparato de succion es equipamento estandar.  
Pero, en caso de material pesado, el tubo de  
diametro mas grande (parts No.00-6604) es  
disponible segun la foto adjunta.  
吸尘装置

|"Overlock" シリーズ用 オプション |

OPTIONS FOR OVERLOCK SERIES / OPCION PARA OVERLOCK SERIES / 包缝系列的附属零件



■ VD 集塵装置  
VENTURI DEVICE  
APARATO ASPIRADOR  
吸尘装置

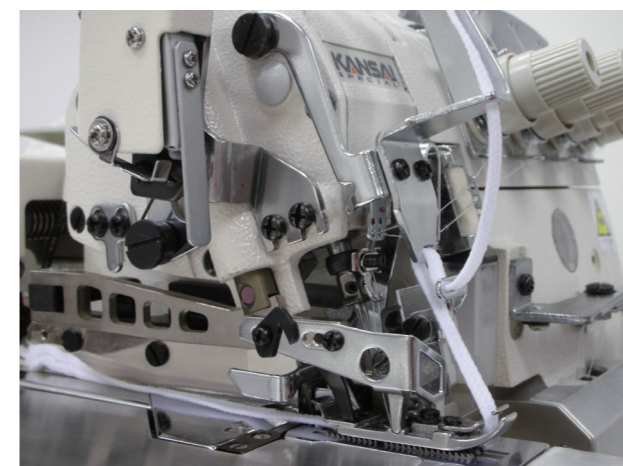
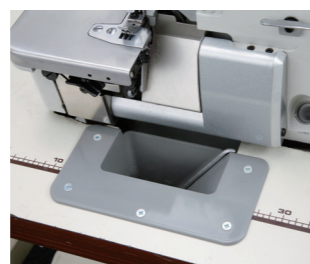

■ ETC-3 電気式テープカッター  
ELECTRIC TAPE CUTTER FOR UK  
CORTADOR DE LA CINTA ELECTRICO PARA UK  
电动式切布装置

■ UK シリーズオプション組合せ  
COMBINATIONS OF OPTIONAL DEVICES

	PATTERN 1	PATTERN 2	PATTERN 3
VD	○	○	○
HTC / VTC	○	○	
FL	○		○
AIR REGURATOR	○	○	○



■ VTC 縦型空環切り装置  
VERTICAL CHAIN CUTTER  
(chain off is cut and is sucked by air at side behind the needle plate)  
CORTADOR DE CADENETA, TIPO VERTICAL  
纵向切线装置

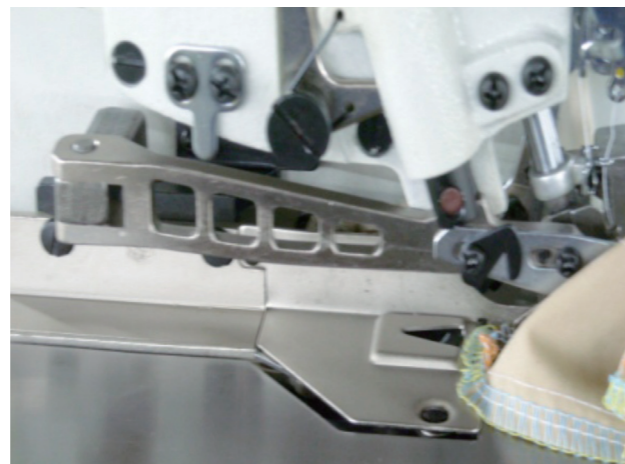

■ HTC 横型空環切り装置  
HORIZONTAL CHAIN CUTTER  
(chain off is cut and is sucked by air horizontally behind the needle plate)  
CORTADOR DE CADENETA, TIPO HORIZONTAL  
横向切线装置

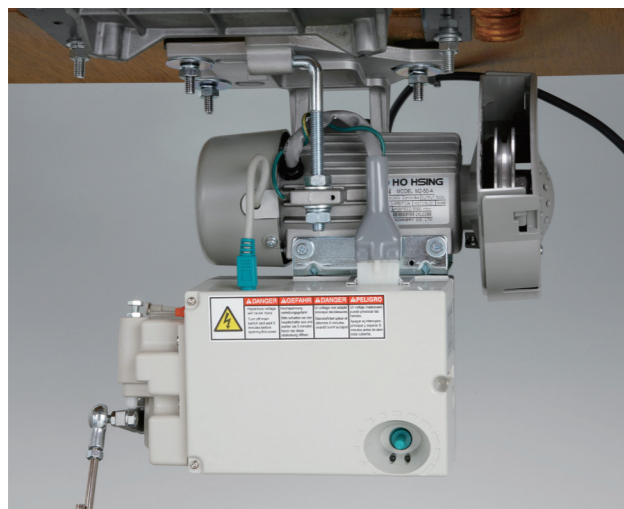

■ MJ-1 簡易型サーボモーター  
ECO SERVO MOTOR  
Servo motor sencillo  
简易马达



■ FL エアー式押え上装置  
AIR TYPE FOOT LIFTER  
LEVANTA PIE NEUMATICO  
气压式抬压脚装置