

NC1103 Series



NC series is a small cylinder bed (circumference 180mm), top and bottom cover stitch machine for high speed and reliable performance.

Major features : Small cylinder bed, differential feed mechanism, stitch tension adjusting mechanism

Applications: overlock cover seaming on sleeve cuffs and hemming children's T-shirts

Features of the machine

Height adjustable needle bar (31, 33mm)

DLC coated needle bar for durability and high speed operation

Double lip oil seal for oil leakage prevention

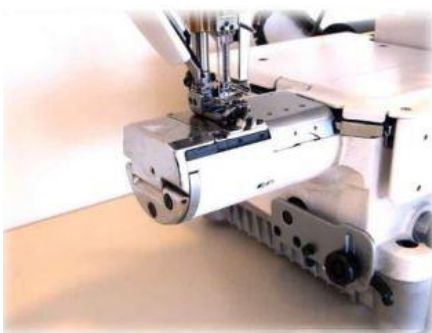
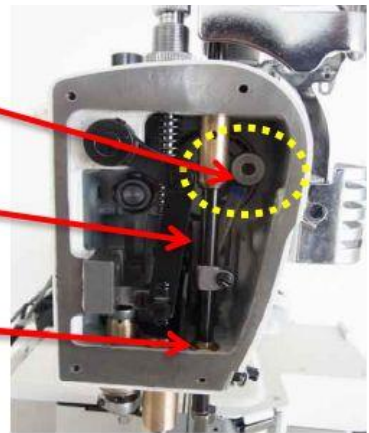

The circumference of the cylinder is 180mm

Equipped with the exterior looper thread take up cam, it is easy to thread and adjust







Subclasses

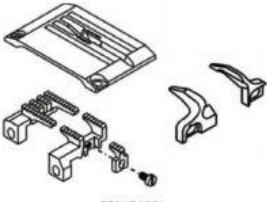

NC1103GCL-UTA

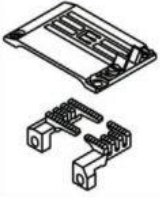

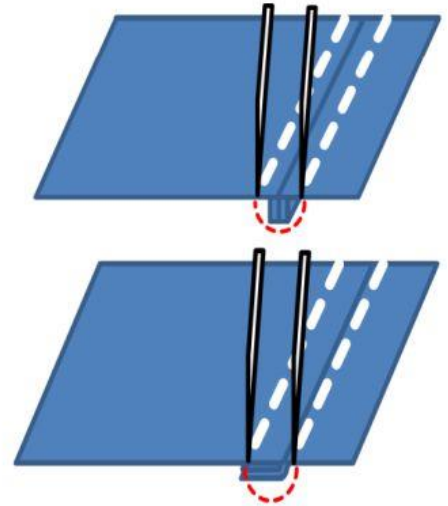

For covering of overlock seams, the machine comes with two gauge sets for both operations below

TYPE	NM1103CL STANDARD GAUGE	NM1103CL STANDARD GAUGE
 C TYPE	 STANDARD	
 CL TYPE	 IN ACCESSORY BOX	





NC1103GDA-UTA

For hemming of sleeves and neck part of T-shirts, the machine comes with two gauge sets for both operations below

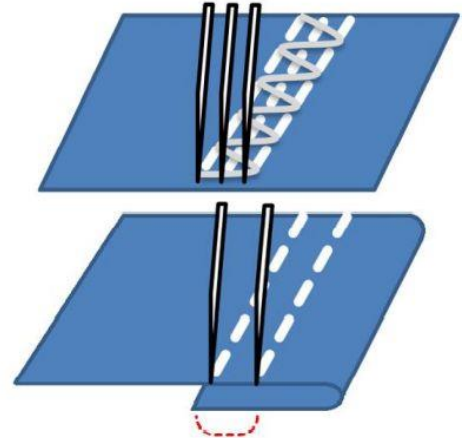
 D TYPE	 STANDARD
 A TYPE	 IN ACCESSORY BOX



Model Name	Application	Material	Needle	No. of threads	Needle gauge	Needle bar stroke	Stitch length	Diff.Feed ratio	Presser foot lift	Maximum Speed
NC1103GDA-UTA NC1103GDA-UTE NC1103GCL-UTA NC1103GCL-UTE	 Top & bottom covering			5	