

Cylinder bed top and bottom covering machine

# NR9803GPEHK-UTA

3 needle, cylinder bed machine with fabric trimmer, pneumatic top and under thread trimmer and smooth puller for attaching pre-closed elastic for under wear.

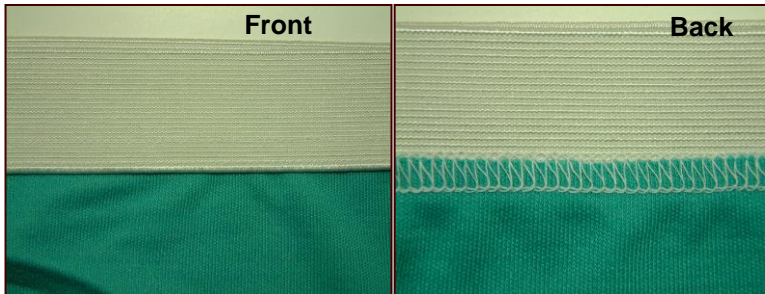

For boxer brief

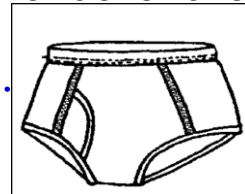

Drop knife system

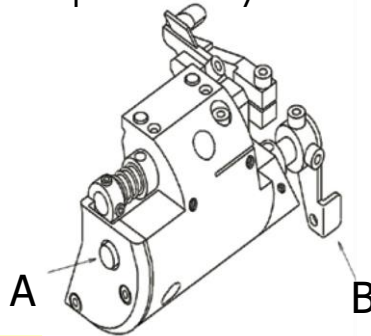

By pushing the button A & B, The height of the knife can be set up under the surface of the needle plate. It is useful for the sewing operation without fabric trimmer.

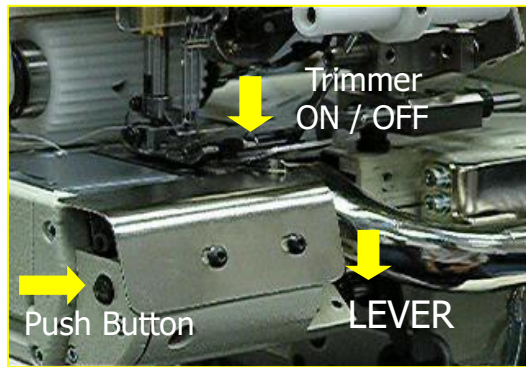

One touch lever system

Easy disengagement of fabric trimmer  
In the time of disengaging fabric trimmer, lift down the lever and hold it by pushing the button.

In the time of reactivating the trimmer, release lever by pushing the button.

Model Name	Application	Material	Needle	No. of threads	Needle gauge	Needle bar stroke	Stitch length	Diff.Feed ratio	Presser foot lift	Maximum Speed
NR9803GPE-HK /UTC-A	Underwear	light to medium	UYx128GAS 10-14	5	7/32, 1/4	33mm	8-16 stitch/inch	0.3-2.9	5mm	4800

